

## Evaluation of Suitability of Raidata Pine (*Pinus Radiata*) For Making Pallets

Anand Nandanwar, M. C. Kiran, K. Ch. Varada Rajulu\* and C. N. Pandey

Indian Plywood Industries Research and Training Institute, IPIRTI, P. B. No 2273, Tumkur road, Bangalore – 560022,

\*Corresponding Author's Email: varadaraju6@gmail.com

### ARTICLE INFO

#### Article history:

Received	11 Mar. 2013
Accepted	16 Apr. 2013
Available online	25 Apr. 2013

#### Keywords:

Suitability figures  
suitability Indices  
pallets  
uniformly distributed load  
Ideal span

### ABSTRACT

Investigations were carried out to study the suitability of *Pinus radiata* (radiata pine) for making pallets and its performance was evaluated. The physical and mechanical properties of radiata pine were evaluated. Suitability indices with respect to mechanical properties of radiata pine were computed. Suitability figure was derived based on suitability indices and the suitability of raidata pine for making of pallets was arrived. Based on the study, the pallets made from raidata pine were classified as 'GROUP II', which is suitable for commonly used pallets and also for dunnage pallets which are used in godowns and warehouses. The performance of pallets was evaluated by simulating the actual work conditions and testing the pallets under uniformly distributed load and also by placing loaded pallets one above the other. The ideal span of forks of fork lift and safe load bearing capacity of wooden pallets were worked out and the suitability of radiata pine for making pallets was established.

© 2013 International Journal of Advanced Research in Science and Technology (IJARST).

All rights reserved.

### Introduction:

The *Pinus radiata* belongs to 'Pinaceae' family, also known as the Insignis Pine or Radiata Pine is a species of pine native to the Central Coast of California. It is the most widely planted pine in the world, valued for rapid growth and desirable lumber and pulp qualities. It is cultivated in various parts of world such as Australia, Chile, New Zealand, United States, United Kingdom etc. Radiata Pine is suitable for a wide variety of uses. It holds screws and nails well and takes paint and stain without difficulty and modern kiln dried timber is very easy to work. Radiata Pine is used in house construction as weatherboards, posts, beams or plywood, in fencing, retaining walls, for concrete. Lower grade timber is converted to pulp to make newsprint. Higher grade timber is used in house construction. Radiata Pine is used chipped to make particle board sheets, commonly used in flooring. Other sheet products are hardboard, softboard and plywood.

The wooden pallets are horizontal and rigid platforms, designed to transport and store products.

Pallets can be handled with a forklift or other lifting mechanisms. Although pallets are available in different sizes and configurations, they fall into two very broad categories namely "stringer" and "block" pallets. Stringer pallets use a frame of three or more parallel pieces of timber. The top deckboards are then affixed to the stringers to create pallet structure. Stringer pallets are also known as "two-way" pallets, since a pallet-jack may only lift it from two directions instead of four. Block pallets are typically stronger than stringer pallets and utilizes both parallel and perpendicular stringers to better facilitate efficient handling. A block pallet is also known as a "four-way" pallet, since a pallet-jack may be used from any side to move it. The wooden pallet is a low cost and durable material handling/transportation platform. The durability and the quality of the wooden pallet are mainly determined by three factors namely lumber quality, nailing quality and manufacturing methods.

With increased industrialization, the requirement of pallets has increased many folds. The timbers having a strength coefficient of 75 (as compared to teak as 100) are considered suitable for pallets based on strength as a beam, stiffness as a beam and suitability as a post (Anon., 1979). Shukla and Rajput (1981) worked out criteria for

classification of timbers as pallets. In their study they classified seventy seven timbers in two groups viz. Group-I: having composite pallet figure above 100 and Group-II: having composite pallet figure between 70 and 100. Timber under Group-I, were recommended for making pallets subjected to heavy/ concentrated load and Group-II for commonly used pallets. The above composite pallet figure is now been adopted for classification of timber in Indian Standard, but with only one class of timber with composite pallet figure of 70 and above.

Dunnage pallets are used in warehoused and godowns to store food grains and other industrial products. For suitability of a timber species for dunnage pallets, minimum value of strength coefficient has been taken as 70 (as compared to teak as 100). Seventy eight species have been recommended for use in making dunnage pallets (Shukla et al., 1984). An Indian standard has also been formulated for the same (Anon., 1993).

The suitability of seven west coast species for pallets was investigated at the forest products laboratory and evaluated on the basis of bending stiffness, free-fall on corner drop, and revolving drum performance (Heebink, 1965). Nandanwar and Naidu (2007) studied on the evaluation of safe working load and optimum width across the fork while lifting wooden pallets with forklifts. The pallets were tested under uniformly distributed load, based on the theoretical findings using the principals of engineering mechanics. The ideal width across fork and safe load bearing capacity of wooden pallets were worked out. The ideal width across fork for safe working loads was determined to achieve uniform stress distribution throughout the surface of pallet and to avoid the breakages or failures due to non-uniform stress distribution.

The timber species radiata pine, taken for the study belongs to the order coniferales of the pine (*Pinaceae*), family, Sub-genus *Diploxylon*. It has a straight trunk, and can reach a height of 30 to 50 meters, with a diameter that can exceed 150 centimeters, owing to its excellent structural stability and strength, it readily accepts screws, nails, and adhesives. These characteristics make it highly suitable for indoor and outdoor applications such as surfaces, housing structures, furniture, moldings and packaging. Due to the strength and high yield of its fiber, it is recognized as a raw material for producing pulp and paper, as well as for making veneers, plywood, fiberboard and particleboard. In this study, Investigations were carried out to study the suitability of radiate pine for making pallets and then their performance was evaluated.

**Materials and Methods:**

Five numbers of pallets made of radiate pine of size 1300mm x 1100mm were taken for the study. The details of pallets and their components are given in Fig.1.

The study was carried out in two parts as given below:-

1. Evaluation of suitability of radiate pine for making pallets
2. Evaluation of performance of pallets made of radiate pine

**1. Evaluation of suitability of radiate pine for making pallets:**

Specimens for testing were drawn from 10 planks of radiate pine. The specimens were prepared and tested for the properties as given in Table 1, by the method given in Indian standard (Anon., 1986). Before testing the specimens of radiate pine were conditioned at ambient temperature of 27 + 2 0C and relative humidity of 65 + 5 % RH. Suitability of radiate pine, for making wooden pallet were arrived based the method given by Shekhar et al., (1972). Based on the properties, suitability indices (S.I.) viz. strength as a beam, stiffness as a beam, shock resisting ability, surface hardness, refractoriness (splitting co- efficient), nail holding power and screw holding power were computed (w. r. t. teak as 100) and are tabulated in Table 2. The suitability indices of teak, reported by Naidu et. al. (2007) was considered for the study. Suitability figure (composite pallet figure) was arrived based on suitability indices as given in Table 3. Based on the composite figure the “Group” of radiate pine was arrived by the criteria given by Shukla and Rajput (1981) for defining suitability of radiate pine for making pallet.1.3.

**Table 1:** Properties of radiate pine

S. No.	Property	Results
A	Static Bending	
1	Stress at Proportional Limit, N/mm <sup>2</sup>	37.85
2	Modulus of Rupture, N/mm <sup>2</sup>	64.72
3	Modulus of Elasticity, N/mm <sup>2</sup>	8168.6
4	Work to max. load, N-mm	7725.79
5	Total work, N-mm	16614.9
6	Work to max. load, N-mm/mm <sup>3</sup>	0.081538
7	Total work, N-mm/mm <sup>3</sup>	0.17001
B	Compression, Parallel, N/mm <sup>2</sup>	
1	Stress at Proportional Limit	17.58
2	Maximum Crushing Strength	37.15
3	Modulus of Elasticity	9147

Cont....

C	Compression, Perpendicular, N/mm <sup>2</sup>	
1	Stress at Proportional Limit	6.85
2	Maximum Crushing Strength	13.6
D	Hardness, N	
1	Tangential	2106
2	Radial	2908
3	End	2030
E	Cleavage, N/mm <sup>2</sup>	
1	Tangential	4168
2	Radial	3465
F	Extraction- Nail , N	
1	Tangential	1420
2	Radial	1130
G	Screw withdrawal , N	
1	Tangential	2990
2	Radial	2780

**Table 2:** Calculation for basic suitability indices

i. Strength as a Beam								
MOR	Adjusting factor (a.f)	Weightage factor (w.f)	Po	MOR at elastic limit	a.f	w.f	P1	(Po+P1)/3
a	b	c	a x b x c	e	f	g	e x f x g	
64.72	1	2	129.44	37.85	1.73	1	65.4805	64.9735
ii. Stiffness as a Beam								
MOE	a.f	w.f	P	P/2				
8.168	1	2	16.336	8.168				
iii. Shock resisting ability								
Work to max load	a.f	w.f	Po	Total Work	a.f	w.f	P1	(Po+P1)/3
0.081538	1	2	0.163076	0.170034	0.47	1	0.079916	0.080997
iv. Hardness								
Radial	a.f	w.f	Po	Tangential	a.f	w.f	P1	Compressive stress at elastic limit
2908	0.166	1	482.728	2106	0.158	1	332.748	6.85
a.f	w.f	P2	End	a.f	w.f	P3	(Po+P1+P2+P3)/5	
1	2	14	2030	0.14	1	292.3	224.2992	
v. Refractoriness (Splitting Co-efficient)								
Radial	a.f	w.f	Po	Tangential	a.f	w.f	P1	(Po+P1)/2
4.618	1	1	4.618	3.465	0.78	1	2.7027	3.66035
vi. Screw Holding Strength								
side	a.f	w.f	Po	end	a.f	w.f	P1	(Po+P2)/3
2990	1	2	5980	2780	0.973	1	2704.94	2894.98
vii. Nail Holding Strength								
side	a.f	w.f	Po	end	a.f	w.f	P1	(Po+P2)/3
1420	1	2	1130	1130	0.973	1	1099.49	743.1633

**Table 3:** Calculation for arriving composite pallet figure of radiate pine

*Formula to compute suitability of radiate pine for making pallets (composite pallet figure) = {(Strength as a beam x 2)+(Stiffness as a beam x 1)+(Shock Resisting ability x 2)+(Hardness x 1)+(Refractoriness x 1)+(Screw & Nail holding power x 1)}/ 8*

Species	Strength as a beam	Weightage	Po	Stiffness as a beam	Weightage	P1	Shock Resisting ability	Weightage	P2	Hardness
	A	B	C=A*B	A	B	C=A*B	A	B	C=A*B	A
Radiata Pine	64.97	2	129.9	8.17	1	8.168	0.08	2	0.162	224.30
Teak	101.473	2	202.9	11.96	1	11.96	0.07009	2	0.14	476.8
Weightage	P3	Refractoriness	Weightage	P4	Screw & Nail holding power	Weightage	P5	suitability figure	Composite pallet figure	
B	C=A*B	A	B	C=A*B	A	B	C=A*B	(P0+P1+P2+P3+P4+P5)/8	Suitability figure of Radiata pine/Teak	
1	224.3	3.66	1	3.66	1819.07	1	1819.1	<b>273.16</b>	<b>73.5565</b>	
1	476.83	5.4696	1	5.47	2273.58	1	2273.6	<b>371.37</b>		

Radiate pine is considered suitable for pallets which have strength coefficient of 73. 6 (as compared to teak as 100) based on strength as beam, stiffness as a beam and suitability as a post (IS: 9340-1979). Pallet manufactured using radiate pine falls under GROUP-II for commonly used pallets (Shukla, 1981).

**2. Evaluation of performance of pallets made of radiate pine**

Three numbers of pallets of size 1300mm x 1100mm, prepared from radiate pine were taken for the study. The details of pallets are given in Fig.1. The Ideal span of forks (in fork-lift) for lifting pallets was

theoretically determined and the shear force and bending moments at different locations of the pallet were calculated. Based on the calculation, maximum and safe load bearing capacity (under uniformly distributed load) on the pallets made from radiate pine was theoretically derived. Simulating the conditions of fork lift, the pallets were tested under uniformly distributed load (UDL) for the theoretically arrived load. The loading (UDL) was done by uniformly distributing dead weights (10 x 10 x 10 cm concrete blocks) by keeping dead weights throughout the pallet one above another. The pallets were also tested for stacking of loaded pallets one above other, simulating the conditions at field.

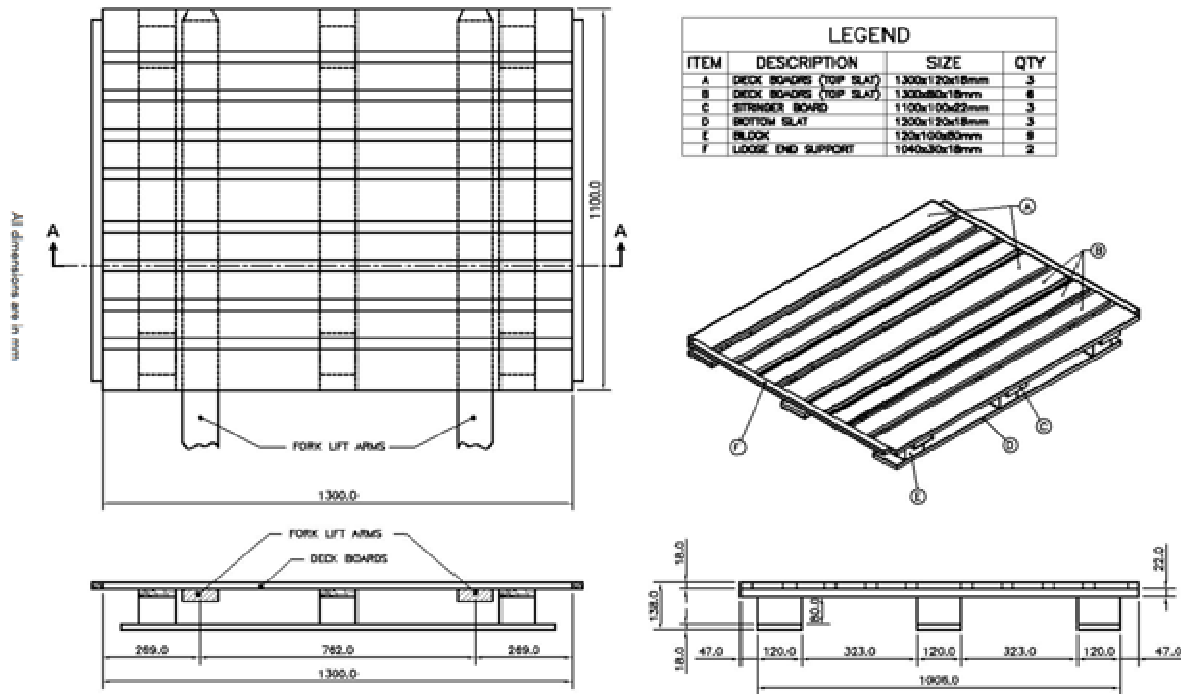

**Fig. 1:** Details of Pallet

**a. Theoretical determination of Ideal span of forks in fork lift for lifting pallets**

Ideal span of forks was theoretically determined with respect to positioning of supports (forks) so that the bending moment is observed least at mid of the span (Ramamurtham, 1995). The width of each fork (b) of fork lift was 100mm. The shear force and bending moment calculations are given in Table 4. The shear force diagram (SFD) and bending moment diagram (BMD) after applying uniformly distributed load over the pallet are given in Fig. 2.

The derivation of equation for span of forks, so that the Bending Moment is minimum at mid span is as given below.

Length of pallet = L  
 Uniformly distributed load (UDL) = w  
 Each vertical reaction = w L/2  
 Hogging Bending Moment (BM) over the supports =  $w a^2 / 2$  ----- (1)  
 Sagging Bending Moment (BM) over the supports =  $w L/2 (L/2 - a) - wL^2/8$   
 =  $w L/2 (L/4 - a)$  ----- (2)  
 Equating (1) & (2) we get =  $a^2 + La = L^2/4$  ----- (3)  
 Distance of edge of pallet to center of support, 'a'  
 = 0.207 L  
 Sagging Bending Moment (BM) at middle point 'o'  
 =  $w/2 (l^2 - 4a^2)$   
 Span of fork lift (l)  
 = {L - (2 x a)} = L - 0.414L = 0.586L

**Table 4:** Theoretical calculations of Bending moment and Shear Force for pallet

Sl. No.	Particular	Formula, unit
1	Length of pallet	L, mm
2	Uniformly distributed load (UDL)	w, N/mm
3	Each vertical reaction	w L/2,N
4	Distance from mid of support to edge of pallet	a, mm
5	Span	L
6	Sagging BM at supports	w a <sup>2</sup> /2, N.mm
7	Hogging bending moment at mid of span	w/2 (l <sup>2</sup> -4a <sup>2</sup> ), N.mm
8	Shear Force calculations	
	a) SF at A & B	0
	b) SF just on the left side of C	- w x 0.207 L, N
	c) SF just on the right side of C	0.207 + 0.5 w L, N
	d) SF just on the left side of D	- 0.207 + 0.5 w L, N
	e) SF just on the right side of D	w x 0.207 L, N
	f) SF at mid span	0

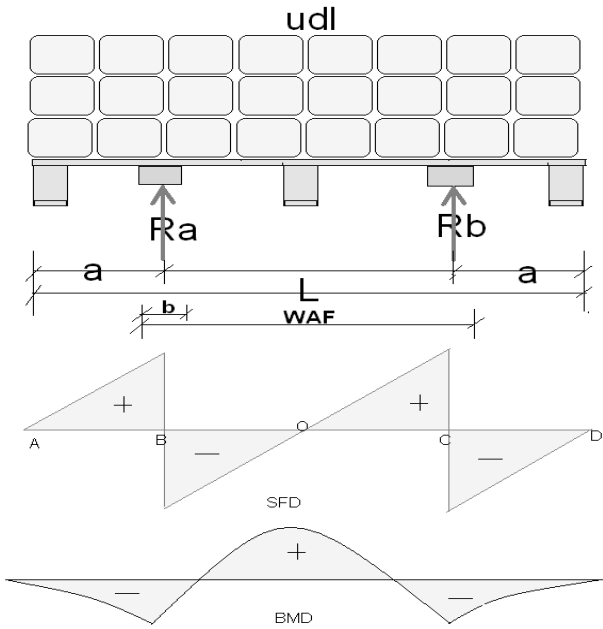

**Fig. 2:** Loading of pallets and Shear force & Bending moment diagrams

**b. Theoretical determination of maximum load (uniformly distributed load) over the pallets.**

While lifting the pallets with the fork-lift, the entire stresses under bending are taken by the pallet members directly resting over the fork-lifts i.e., deckboards as described in the fig. 1. Negligible or no stresses are taken by the other members of the pallets. For the purpose of calculation the effective width of the

deck board is taken as the sum of widths of the deck boards. The pallet while lifting with fork lift behaves as series of beams with equal overhangs. The intermediate supports were adjusted in such a way that the bending moment is observed minimum at mid of the span in order to achieve minimum sagging of the materials loaded over the pallet.

$$\text{Bending Equation } M/I = MoR/y \text{ ----- (4)}$$

Where, M= Maximum bending moment at mid of the span =  $wl^2/8$

$$I = \text{Moment of Inertial} = bt^3/12$$

MoR = Modulus of rupture under bending of the given species of wood, MPa

y = Distance from neutral axis

Equating the equation (4),

$$\frac{w/2 (l^2 - 4a^2)}{bt^3/12} = \frac{MoR}{t/2}$$

Where,

w = UDL, N/mm

b = Sum of widths of deckboard planks, mm

t = Thickness of deckboard, mm

$$\Rightarrow w = \frac{MoR \times bt^2}{3((l^2 - 4a^2))} \text{ ----- (5)}$$

Total load over the pallet, W = wL

**Table 5:** Theoretical determination of Safe UDL over pallet

Thickness of deck board,	t	=	18	mm
Sum of widths of deck board planks,	b	=	840	mm
Width of pallet,	B	=	1100	mm
Length of pallet,	L	=	1300	mm
length of overhang on either side	a	=	269.1	mm
	2a	=	538.2	mm
Span length of supports	l	=	761.8	mm
Modulus of rupture of radiate pine,	MoR	=	64.4	N/mm <sup>2</sup>
Moment of Inertia,	I	=	408240	mm <sup>4</sup>
Distance from neutral axis,	y	=	9	mm
Maximum UDL over entire pallet N/mm,	w	=	40.2	N/mm
Total load over pallet in N,	W	=	52257.3	N
Factor of safety	F	=	2	
Safe UDL over entire pallet in N/mm,	w <sub>safe</sub>	=	20.10	N/mm
Total load (safe) over pallet in N,	W <sub>safe</sub>	=	26128.7	N

strength as a beam, stiffness as a beam, shock resisting ability, surface hardness, refractoriness (splitting co-

### c. Testing of pallets

Based on the theoretical findings the pallets were placed over supports simulating the conditions of fork lift. The pallets were loaded after keeping the pallets in position with predetermined Span of fork lift arms. The width of each fork of fork lift was 100mm. The length of fork is approximately 1200mm. The pallets were held exactly at horizontal position (tested with spirit level). The loading (UDL) was done by exactly keeping dead weights one above another with the help of (10 x 10 x 10 cm) cube concrete blocks and the load was distributed uniformly throughout the pallet.

The pallets were loaded for the predetermined total load of 26000 N, which is the total safe load over pallet as derived in equation (5) and the pallets were examined for failures and deformation.

The pallets were also tested for stacking of pallets one above other. Three numbers of pallets were stacked one above the other after loading each pallet for 10000 N and the pallets were examined for failures and deformation. In all the cases mentioned above, no failure was observed.

### Results and Discussion:

The physical and mechanical properties of radiate pine are given in Table 1. The suitability indices viz.

efficient), nail holding power and screw holding power computed w r t teak (as 100), based on the physical and mechanical properties of radiate pine are given in Table 2 and Table 3. Suitability figures arrived based on suitability indices given in Table 4, arrived by the method given by AC Shekhar et al., (1972). The radiate pine was grouped under “Group II”.

The Ideal span of fork was theoretically determined with respect to positioning of supports so that the bending moment is observed minimum for the mid of the span. The theoretical calculations of Span, Bending moment and Shear Force for pallet are given in Fig. 2 and Table 4. Theoretical determination of Safe UDL over pallet is given in Table 5. Theoretically as well as practically, it was found that the pallet made from radiate pine can safely lift load of 20 N/mm (for the tested type/construction).

### Conclusion:

In the study the suitability of radiate pine for making pallets and its performance was evaluated. The suitability figures based on suitability indices were derived and the suitability of Radata pine for use as pallets was established. The pallets made from radata pine were classified as ‘GROUP II’, which is suitable for commonly used pallets and also for Dunnage pallets

which are used in Godowns and Warehouses. The Ideal span of fork was theoretically determined and it was

found that the pallet made from radiata pine can safely lift load of 20 N/mm for the tested type/construction.

#### **Acknowledgement:**

This paper is published with the permission of the Director, IPIRTI, Bangalore.

#### **References:**

1. Nandanwar Anand and Naidu M Venugopal (2007). Study on the evaluation of safe working load and optimum width across the fork while lifting wooden pallets with fork lifts' was published in J. Ind. Acad. Wood Sci., Vol. 4 (1&2).
2. Naidu Venugopal M., Nandanwar Anand, Pandey C. N., Shyamsundar K., Kamal S. Z. M., Narasimha Murthy (2007). Testing of American hardwood species to promote their specialized uses and trade in India. IPIRTI project report SP/62/AHEC/2007, Bangalore.
3. Heebink, T. B. (1965). Suitability of seven West coast species for pallets. U. S. Forest service research paper FPL 22. Forest Products Laboratory. Wis.. US
4. Anon. (1986). Methods of testing of small specimens of timber, IS 1708. Bureau of Indian Standards, New Delhi.
5. Anon. (1989), Specification for non-expandable general purpose flat pallets for through transit of goods, IS:7276, Bureau of Indian Standards, New Delhi.
6. Anon. (1993). Expendable pallets – Specification, IS 9340. Bureau of Indian Standards, New Delhi.
7. Anon.(1993). Dunnage pallets - Ware housing – Specification, IS 13714. Bureau of Indian Standards, New Delhi.
8. Ramamurtham S. (1995). Strength of Materials, Dhanpat rai and sons, New Delhi.
9. Sekhar, A. C; Gulati, A. S (1972). Suitability indices of Indian timbers for industrial and engineering uses. Indian Forest Records, Timber Mechanics 2(1): 1-62
10. Shukla, N.K., Kumar Satish and Sanyal, S.N. (1984). Timber for dunnage pallets. J. Timb. Dev. Assoc. 30 (4): 15-25.
11. Shukla, N.K. and Rajput, S.S. (1981). On the classification of timbers for pallets, Packaging India 13 (2): 20-26.